

3175

Paper Stock/Process Pump



3175

Designed to Handle the Toughest Jobs in the Pulp & Paper and Process Industries

- Capacities to 28,000 GPM (6360 m³/h)
- Heads to 350 feet (107 m)
- Temperatures to 450°F (232° C)
- Pressures to 285 PSIG (1965 kPa)

Design Features

- Back Pull-Out
- Fully Open Impeller
- External Impeller Adjustment
- Renewable Wear Parts
- Maximum Sealing Flexibility
- Heavy Duty Construction
- Maximum Parts Interchangeability
- Optional i-ALERT® Condition Monitoring

Applications

- **Pulp & Paper** - Paper Stock through 6% Consistency, Black Liquor, Hydropulper and Broke Service, Low NPSH Digester Circulation, Blow Tank to Screens, Primary Screens Rejects, High Density Chlorine Tower to Washer, Flotation Cell Circulation
- **Chemical** - Evaporator and Reboiler Circulation, Slurry Services
- **Petroleum** - Corrosive/Abrasive Crude, Catalyst Slurry, Coke Fines
- **Steel** - Mill Descaling, Waste Treatment, Venturi Scrubber, Electro-Galvanizing Recirculation
- **Food** - Fruit Pulps, Grain Mash and Spent Grains, Evaporator Recirculation, Beet and Cane Sugar, Corn Products
- **General** - Waste Treatment, Air Pollution Abatement, Acid Mine Water, Textile Slurries



Wide Range of Materials

Stocked in Cast Iron and 316 Stainless Steel. Available in any machinable alloy including 317SS, 317LSS, 316LSS, Alloy 20, CD4MCuN, 6-7% moly, Titanium, Hastelloy B and C



A Proven Performer

Since its introduction in 1968, the 3175 has proved itself over and over again. Thousands of installations attest to its remarkable performance even under the severest conditions. And for ease of maintenance, it can't be beat. Customers know they can rely on the 3175 for minimum downtime, increased productivity.



A 3175 installed in a major chemical plant.



Black liquor circulation pump (3175 XL) on spring-loaded baseplate.



Model 3175 handling paper stock



Taking suction from a large stock tank... the 3175 is the preferred pump in the Pulp & Paper Industry



3175's on process service such as multi-effect evaporators.



Preventive maintenance is fast and easy on a 3175.

Long Life/Low Maintenance/Reliable Operation

External Impeller Adjustment

Impeller clearance can be easily reset by external adjustment to maintain hydraulic performance. Delivers long time energy savings, while downtime is kept to a minimum.

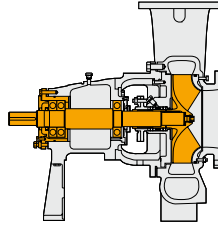

Optional TaperBore™ Seal Chamber

Features an enlarged bore for improved lubrication and cooling of the mechanical seal. The tapered throat keeps solids away from seal faces and from building up in the chamber. Seal life is remarkably extended.



Renewable Wear Parts

Low maintenance costs because all wear parts...suction sideplate, impeller, stuffing box cover, shaft sleeve and throat bushing...are easily replaced.

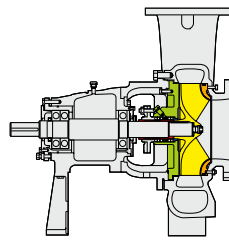

Fully Open Impeller

Special warped vane, heavy duty open type for paper stock handling. Back pump-out vanes reduce stuffing box pressure, and help prevent solids from entering sealing chamber.



Heavy Duty Shaft

Designed for continuous service under most severe operating conditions—dry end broke, repulper, hydropulper, blowtank. Low deflection at maximum load for long seal and bearing life, extended MTBF.



Latest i-ALERT Technology

Optional Bluetooth device monitors the health of the equipment, including runtime, temperature, and vibration.



Standard Labyrinth Oil Seals

Prevent contamination of lubricant for extended bearing life.



Maximum Sealing Flexibility

Dynamic Seal

**For elimination of mechanical seal problems;
reduced maintenance**

Goulds Dynamic Seal pumps are designed to handle the tough applications where conventional mechanical seals or packing require outside flush and constant, costly attention. The major advantage is that external seal water is not required, thus eliminating leakage, pumpage contamination, product dilution and problems associated with piping from a remote source.

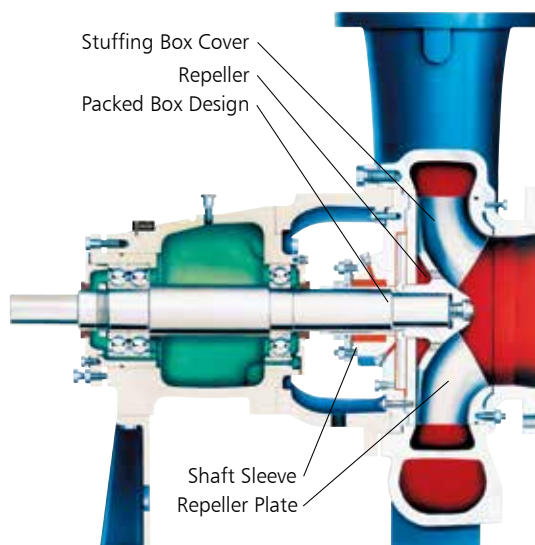

Standard Model 3175 pumps can be fitted with a repeller between the stuffing box and impeller. At startup, the repeller functions like an impeller and pumps liquid from the stuffing box. When the pump is shut down, a conventional static seal prevents pumpage from leaking.

The 3175 is easily field converted to Dynamic Seal. Goulds retrofit kit includes repeller, stuffing box cover, repeller plate, shaft sleeve and choice of static sealing arrangement.

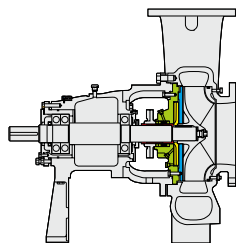

TaperBore™ Seal Chamber

Goulds optional TaperBore™ seal chamber features an enlarged bore for improved lubrication and cooling of the mechanical seal. The design features a tapered throat and a vane particle ejector to keep solids away from seal faces and from building up in the seal chamber. Seal life is remarkably extended.

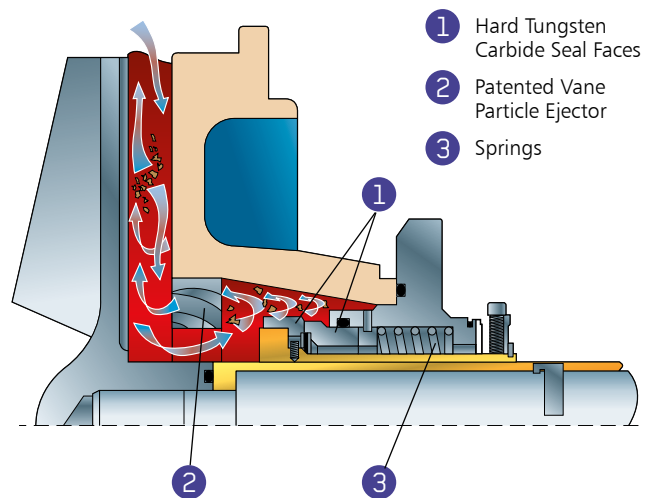

Goulds TaperBore™ seal chamber and cartridge mechanical seal. A full range of other seal types is available.

Parts List and Materials of Construction

Item Number	Part Name	Material			
		All Iron/ 316SS Trim	All 316SS	All 317SS	All CD4MCu
100	Casing	Cast Iron	316SS	317SS	CD4MCu
101	Impeller	316SS	316SS	317SS	CD4MCu
105 ¹	Lantern Ring	Glass-Filled PTFE			
106	Stuffing Box Packing	Graphitized Non-Asbestos Fibers			
107	Gland, Packed Box	316SS	316SS	317SS	316SS
108	Frame Adapter	Cast Iron			
109A	Bearing End Cover—Coupling End	Cast Iron			
112A	Thrust Bearing	Duplex Angular Contact—Back-to-Back			
119A	Bearing End Cover—Inboard	Cast Iron			
122	Shaft	AISI 4140		316SS	AISI 4140
125	Stuffing Box Throat Bushing	Cast Iron	316SS	317SS	CD4MCu
126 ²	Shaft Sleeve (Packed Box)	316SS Hard Metal Coated		317SS	316SS HMC
134A	Bearing Housing	Cast Iron			
136	Bearing Locknut and Lockwasher	Steel			
168A	Radial Bearing	Steel			
174	Suction Piece	Cast Iron	316SS	317SS	CD4MCu
176	Suction Sideplate	Cast Iron	316SS	317SS	CD4MCu
178	Impeller Key	AISI 303			
178J	Repeller Sleeve Key (Dynamic Seal)	AISI 303			
184	Stuffing Box Cover	Cast Iron	316SS	317SS	CD4MCu
198	Impeller Screw	316SS		317SS	316SS
228	Bearing Frame	Cast Iron			
241	Frame Foot	Cast Iron			
262	Repeller (Dynamic Seal)	316SS	316SS	317SS	CD4MCu
264	Gasket—Backplate to S.B. Cover (Dynamic Seal)	Aramid Fiber with EPDM Rubber Binder			
265	Stud/Nut—Repeller Plate to S.B. Cover (Dynamic Seal)	AISI 303/AISI 304			
332A	Labyrinth Oil Seal—Coupling End	Bronze			
333A	Labyrinth Oil Seal—Inboard	Bronze			
351	Gasket—S.B. Cover to Casing	Aramid Fiber with EPDM Rubber Binder			
353	Gland Stud/Nut	AISI 303/AISI 304			
356E	Stud/Nut—Suction Sideplate	AISI 303/AISI 304			
360	Gasket—Inboard Bearing End Cover	Vellumoid			
360A	Gasket—Outboard Bearing End Cover	Vellumoid			
360P	Gasket—Sideplate to Casing	Aramid Fiber with EPDM Rubber Binder			
412	O-ring—Shaft Sleeve	PTFE			
412B	O-ring—Impeller Screw	PTFE			
412C	O-ring—Suction Sideplate	Buna-N			
412U	O-ring—Repeller (Dynamic Seal)	PTFE			
444	Backplate (Dynamic Seal)	316SS	316SS	317SS	CD4MCu
494	Cooling Coil (Optional)	Copper/Steel			
496	O-ring—Bearing Housing	Buna-N			
761B	†-ALERT Condition Monitor	Stainless Steel/Epoxy			

1. Group XL only: Cast Iron for All 316SS trim, 316SS for All 316SS, 317SS for All 317SS, 316SS for All CD4MCu.

2. Standard sleeve for 317SS pumps with packed box is 317SS and is not hard-coated. Standard sleeve for pumps with 2 mechanical seal is 316SS (317SS on all 317SS).

Materials of Construction

Cast Iron	Cast Iron—ASTM A48, Class 20, 25, 30	303SS	303 Stainless Steel—ASTM A582 Type 303
316SS	316 Stainless Steel— (Cast) ASTM A743 Gr CF-8M (Wrought) ASTM A276 Type 316	304SS	304 Stainless Steel—ASTM A276 Type 304
		317SS	317 Stainless Steel—ASTM A743 Gr CG-8M
		CD4MCu	Iron-Chrome-Nickel Alloy—ASTM A743 Gr CD4MCu
		Steel	Carbon Steel—ASTM A322 Gr 4140

Sectional View

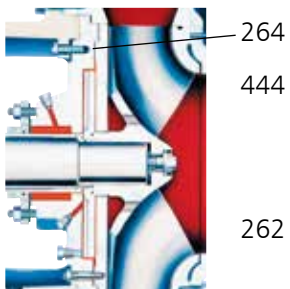
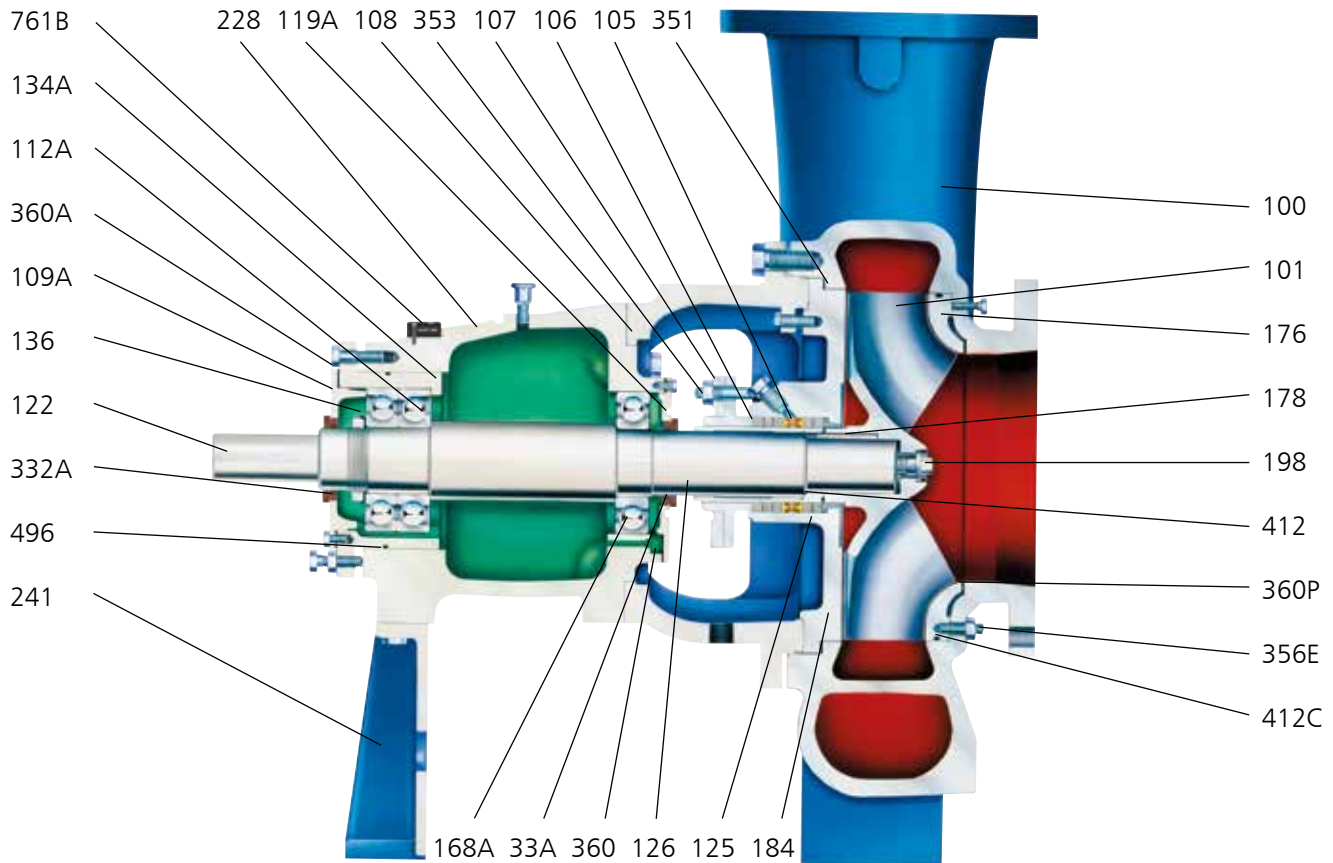

Dynamic Seal Option



Optional Suction Piece

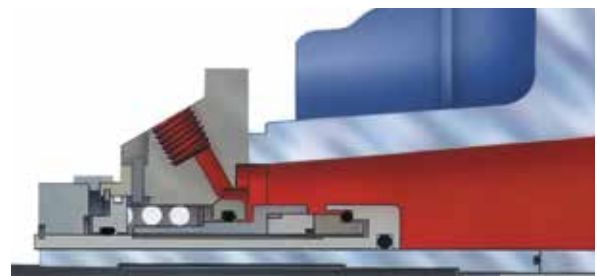

TaperBore™ Seal Chamber and Mechanical Seal Option



Optional High Efficiency Finned Cooler

3175 Paper Stock / Process Pumps

Heavy Duty Design Features for Handling the Toughest Services with i-alert® Patented Intelligent Monitoring

Latest i-alert Technology

Optional Bluetooth device monitors the health of the equipment, including runtime, temperature, and vibration.

LABYRINTH SEALS

Standard Labyrinth Oil Seals prevent premature bearing failure caused by lubricant contamination and loss of lubricant.

HEAVY DUTY SHAFT

Designed for minimum deflection at maximum load. Dry shaft design—sealed by O-rings at sleeve / impeller hub and impeller bolt.

RENEWABLE SHAFT SLEEVE

Hook-type sleeve is positively driven by impeller key. Free to expand with temperature changes.



OPTIONAL HIGH EFFICIENCY FINNED COOLER

Requires minimum cooling water; easily cleaned to maintain bearing cooling efficiency. Corrosion resistant materials standard.

LUBRICATION FLEXIBILITY

Oil lubrication standard. Grease and oil mist optional.

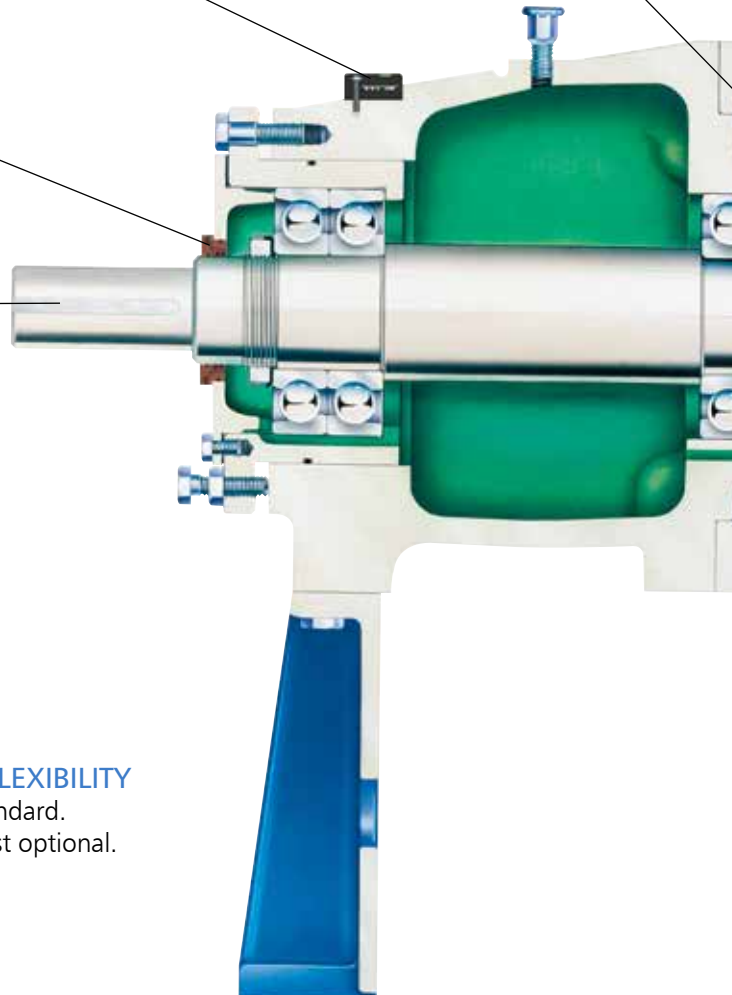

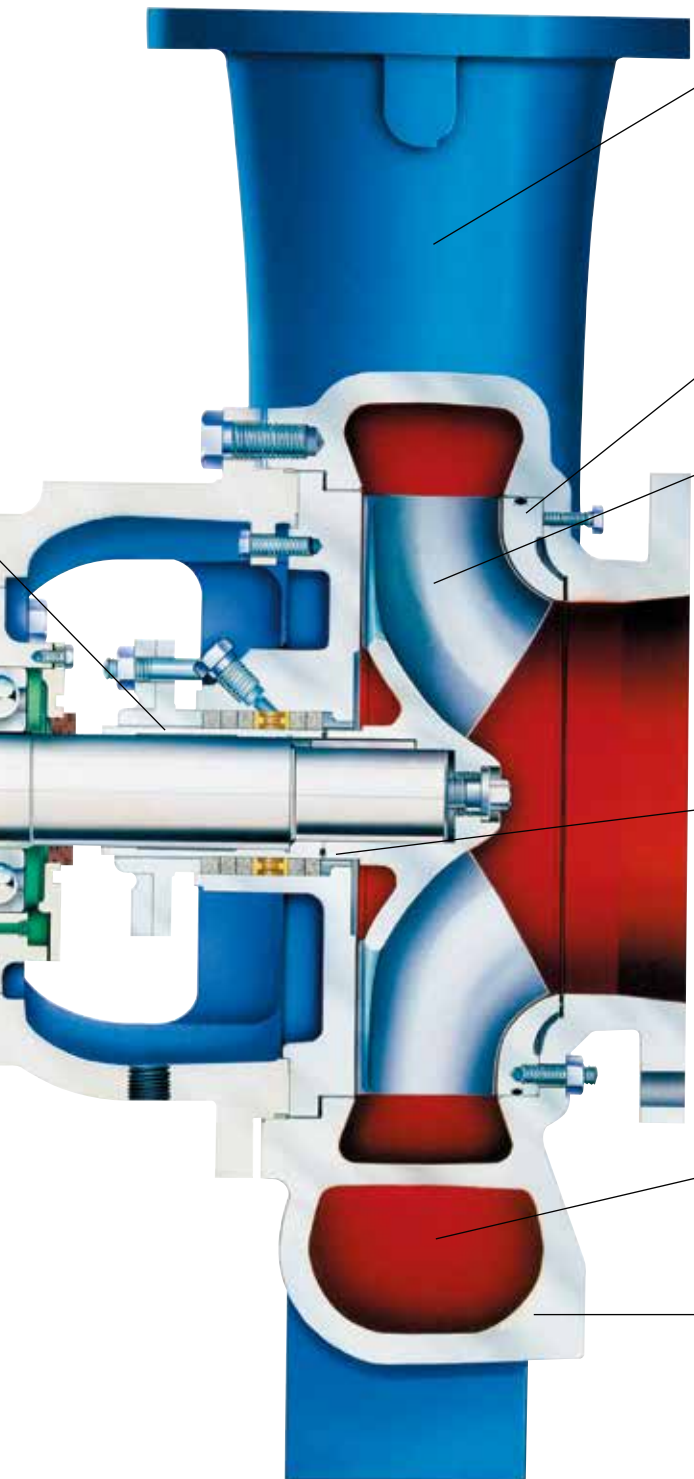

VERTICAL CENTERLINE DISCHARGE

Self-venting design for air handling. Casing provides maximum piping support.

RENEWABLE SIDEPLATE

Heavy suction sideplate minimizes maintenance costs. Positively sealed with O-ring and gasket.

FULLY OPEN IMPELLER

Designed for full range of services. Back pump-out vanes minimize stuffing box pressure, help prevent solids from entering seal chamber.

REPLACEABLE STUFFING BOX BUSHING

Minimizes packing and sleeve maintenance.

DUAL VOLUTE CASING

Provided on sizes as required to minimize radial unbalance for long packing, mechanical seal and bearing life.

EXTRA THICK WALL SECTIONS

For extended wear life and reduced maintenance.

Hydraulic Coverage

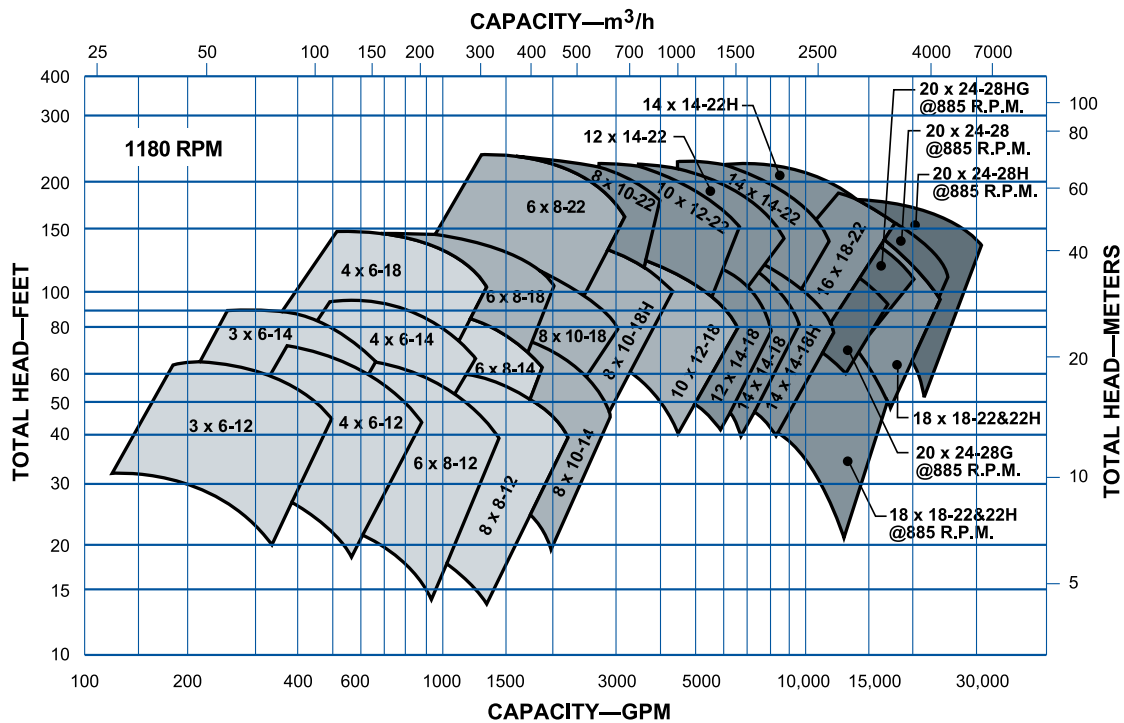
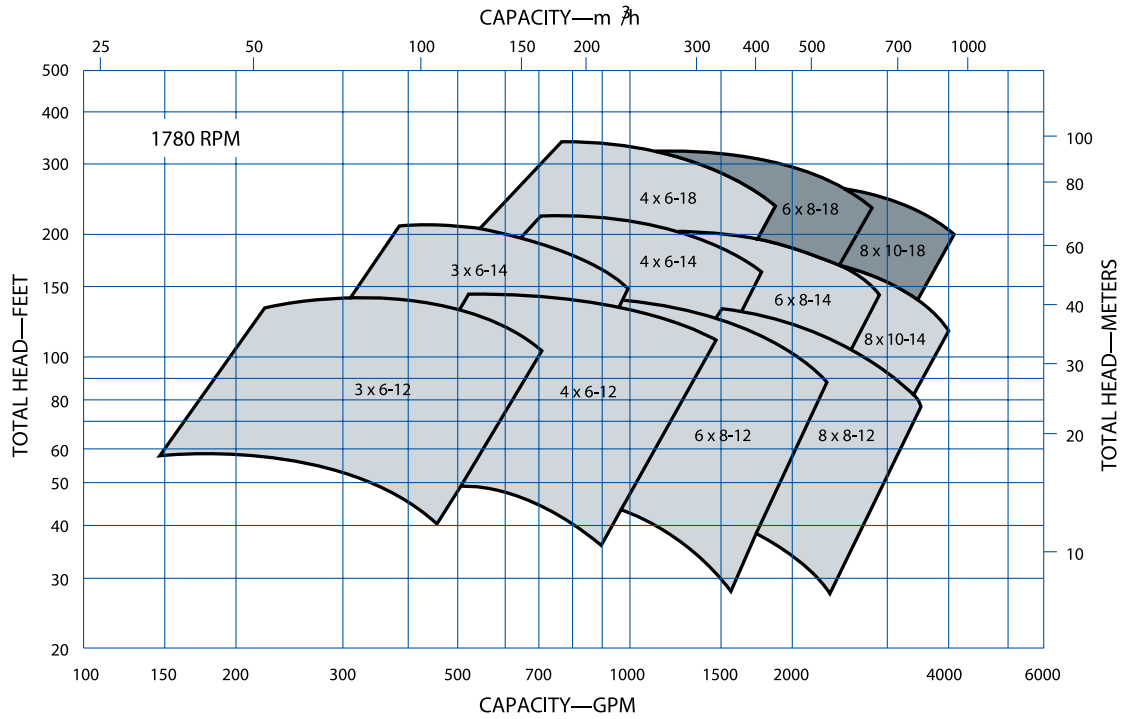

Modular Interchangeability

Minimum Parts Requirements

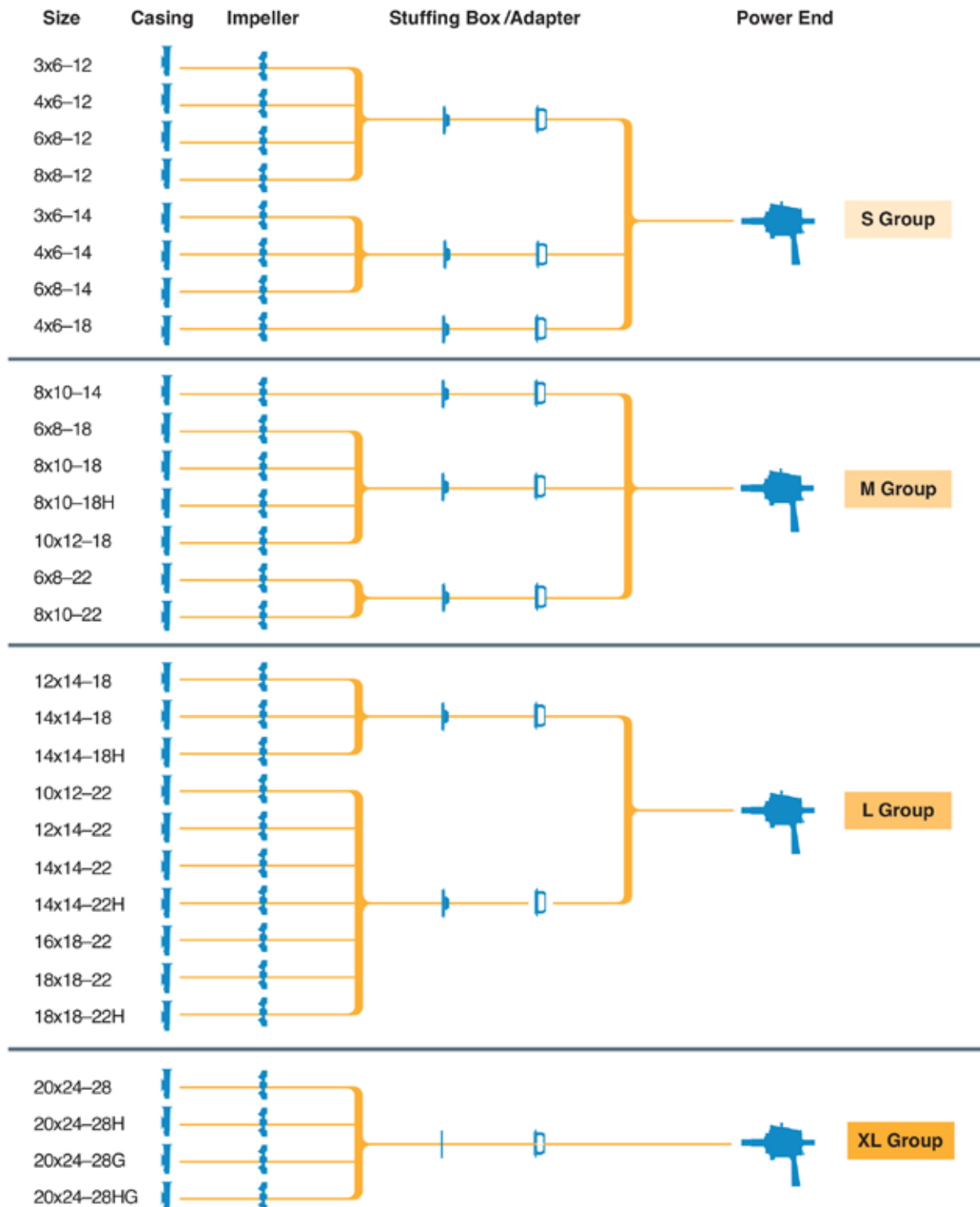

Dimensions

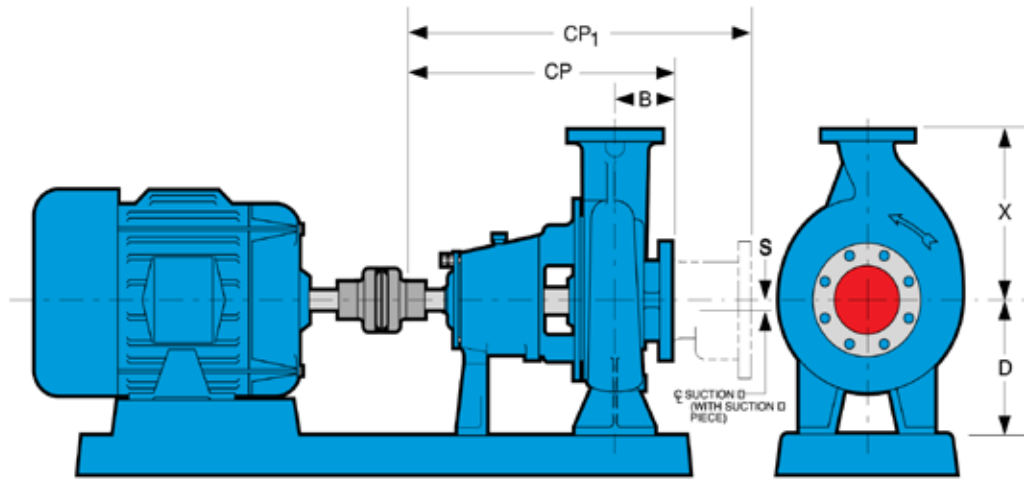

DIMENSIONS															
Group	Pump Size	Disch. Size	Suct. Size	Suct. Size*	D	X	B	CP	CP ₁	S	Shaft Diameter at Coupling	Bare Pump Weight* Lbs. (kg.)			
S	3x6-12	3	6	8	—	13 (330)	7 1/4 (184)	39 1/4 (1010)	51 (1295)	1 (25)	1.875 (47.63)	745 (338)			
	4x6-12	4	6	10	12 1/2 (318)	14 1/2 (368)						810 (367)			
	6x8-12	6	8	—	—	16 (406)				975 (442)					
	8x8-12	8	8	12	14 1/2 (368)	19 (483)	8 1/8 (206)	41 1/8 (1045)	52 1/8 (1330)	2 (51)	1.874 (47.60)	1205 (547)			
	3x6-14	3	6	8	12 1/2 (318)	13 (330)	7 1/4 (184)	39 1/4 (1010)	51 (1295)			1 (25)	850 (386)		
	4x6-14	4	6	10		14 1/2 (368)				925 (420)					
	4x6-18	4	6	10		16 (406)				1050 (476)					
6x8-14	6	8	12	16 (406)		1100 (499)									
M	6x8-18	6	8	12	14 1/2 (368)	18 (457)	7 1/4 (184)	39 1/4 (1010)	51 (1295)	2 (51)	2.375 (60.33)	1525 (692)			
	6x8-22	6	8	12	17 (432)	21 (533)						1700 (771)			
	8x10-14	8	10	14	14 1/2 (368)	19 (483)						1550 (703)			
	8x10-18	8	10	14	14 1/2 (368)	21 (533)	8 1/8 (206)	41 1/8 (1045)	53 (1346)			1600 (726)			
	8x10-18H	8	10	14	17 (432)	21 (533)						1725 (782)			
	8x10-22	8	10	14	17 (432)	23 (584)	1800 (816)								
	10x12-18	10	12	16	20 (508)	23 (584)	1900 (862)								
L	10x12-22	10	12	16	20 (508)	25 (635)	8 1/8 (206)	41 1/8 (1045)	53 (1346)	2 (51)	3.375 (85.73)	2050 (930)			
	12x14-18	12	14	18	20 (508)	25 (635)						2000 (907)			
	12x14-22	12	14	18	20 (508)	27 (686)				2350 (1066)					
	14x14-18	14	14	20	20 (508)	27 (686)	8 1/8 (225)	42 1/2 (1080)	55 (1397)	3 (76)	3.374 (85.70)	2125 (964)			
	14x14-18H	14	14	20	20 (508)	27 (686)						2800 (1270)			
	14x14-22	14	14	20	22 (559)	30 (762)	12 1/2 (324)	47 7/8 (1205)	—	—	—	3800 (1724)			
	14x14-22H	14	14	20	—	—						4500 (2041)			
	16x18-22	16	18	—	28 (711)	32 (813)						9 3/4 (251)	43 1/2 (1105)	—	—
18x18-22	18	18	—	28 (711)	34 (864)	16 1/8 (422)						50 1/4 (1276)	—	—	
XL	20x24-28	20	24	—	30 (762)	40 (1016)	17 1/2 (445)	66 1/4 (1695)	—	—	3.875 (98.43)	5300 (2404)			
	20x24-28H											3.874 (98.40)			
	20x24-28G														
	20x24-28HG														

*With Suction Piece

All dimensions in inches and (mm). Not to be used for construction.

Construction Details

		S Group	M Group	L Group	XL Group
Temperature Limits	Maximum Liquid Temperature—Oil Lubrication Without Cooling	250°F (121°C)			
	Maximum Liquid Temperature—Oil Lubrication with Frame Cooling	350°F (177°C)—Cast Iron 450°F (232°C)—Steel			
	Maximum Liquid Temperature—Grease Lubrication	250°F (121°C)			
Power Limits	HP (kW) per 100 RPM—904L and Alloy 20 Construction	9.52 (7.10)	23.8 (17.8)	63.5 (47.4)	113.6 (84.7)
	HP (kW) per 100 RPM—Constructions other than Alloy 20	17.4 (13.0)	31.9 (23.8)	82.2 (61.3)	129.0 (96.2)
Shaft Diameter	At Impeller	1 7/8 (48)	2 1/4 (70)	3 1/8 (86)	3 7/8 (98)
	Under Shaft Sleeve	2 1/2 (64)	3 5/8 (84)	4 7/8 (109)	5 (127)
	At Coupling	1 7/8 (48)	2 3/4 (60)	3 1/8 (86)	3 7/8 (98)
	Between Bearings	3 1/8 (79)	4 (102)	4 7/8 (124)	6 (152)
Sleeve	O.D. through Stuffing Box	3 (76)	3 1/8 (95)	4 1/8 (121)	5 1/8 (140)
Bearings	Thrust (Coupling End)	SKF 7313 BECBY	SKF 7317 BEGAM	SKF 7222 BECBM	SKF 7326 BECBM
	Radial (Inboard or Pump End)	SKF 6313	SKF 6317	SKF 6222	SKF 6326
	Bearing Span	12 1/4 (311)	11 11/16 (297)	11 1/8 (283)	18 (457)
	Shaft Overhang	10 11/16 (271) to 11 1/2 (301)	11 11/16 (290) to 12 3/8 (319)	11 7/8 (302) to 13 3/8 (344)	19 (483)
Stuffing Box	Bore	4 (102)	4 1/4 (121)	5 1/4 (146)	7 1/2 (191)
	Depth—to Stuffing Box Bushing	3 11/16 (94)			
	Packing Size	1/2 x 1/2 (13 x 13)			1 x 1 (25 x 25)
	Distance from End of Stuffing Box to Nearest Obstruction	3 1/8 (79)		3 1/8 (83)	3 3/8 (95)

All dimensions in inches and (mm). Not to be used for construction.

World Class Service; Value-Added Capabilities

Goulds is much more than a manufacturer and marketer of pumps. Capabilities that extend from project consultation to on-site testing and start-up evaluation are available to every customer. Many specialized services from Goulds are only evident after the sale and installation of the product: parts, repair, training and more.

Research and Development

Goulds continually tests and evaluates every product. The R&D team constantly seeks innovative designs, new materials and system improvements.



Fabrication and Casting

The most advanced foundry and fabrication concepts are utilized to improve quality. Our own advanced foundries produce metals from cast iron to Hastelloy including the new generation of high alloys. Because we're not dependent on outside suppliers, we have total control over metallurgical quality.



Repair and Overhaul

Goulds PRO (Pump Repair and Overhaul) Services® Centers repair all types of rotating equipment. Each facility also has special diagnostic equipment to facilitate preventive maintenance. Let the nearest PRO Services® Center demonstrate repair as an economical alternative to replacement.



Field Service

A staff of highly specialized installation, training and commissioning engineers is available to insure each projects' successful completion and start-up.

Training

Goulds Pumps offers the most advanced training program of its kind in the industry including product training, maintenance schools, and PRIME™ seminars. Each seminar is structured as an ongoing educational experience for customers around the world.

Parts Availability

Goulds Pumps Distribution Centers are strategically located worldwide, and are committed to the ready availability of repair parts.

Service and Support

In addition to direct sales offices around the world, over 200 authorized Goulds representatives and distributors are totally committed to meeting customers' requirements.

3180/85



Top: A Model 3180 installed in a North American recycle mill.

Middle: Model 3180XL on difficult high temperature service. Spring-mounted baseplate provided to compensate for thermal expansion.

Left: Cooling water pump for primary turbine at a power plant in the Middle East.

Goulds 3180/85

Worldwide Experience on Process Pumping Services

When Goulds developed the 3180, we utilized 140 years of pump design experience to ensure it would have unmatched mechanical reliability. Today, installations around the world attest to its remarkable performance. The 3180 is the heavy duty process pump designed to handle all of your tough process pumping applications.

World-class Pump Line

Model 3180 is built to ANSI standards.

- ◆ ANSI class 125/150 lb. flange drilling
- ◆ Inch-dimensioned O.D. of mechanical seal sleeve
- ◆ Inch-dimensioned bearing locknut
- ◆ Inch-dimensioned shaft and keyway at coupling

Model 3185 (built to Metric standards)

- ◆ ISO or JIS 16 bar flange drilling
- ◆ mm-dimensioned O.D. of mechanical seal sleeve
- ◆ mm-dimensioned bearing locknut
- ◆ mm-dimensioned shaft and keyway at coupling
- ◆ International design 3185 pumps comply to ISO 5199 with eight sizes conforming to ISO 2858 dimensions. Metric fasteners and fittings used throughout.

Model 3181/86

For high pressure/
temperature services

- ◆ Centerline mounted
- ◆ Same hydraulics as 3180/85
- ◆ Power End components are interchangeable with 3180/85

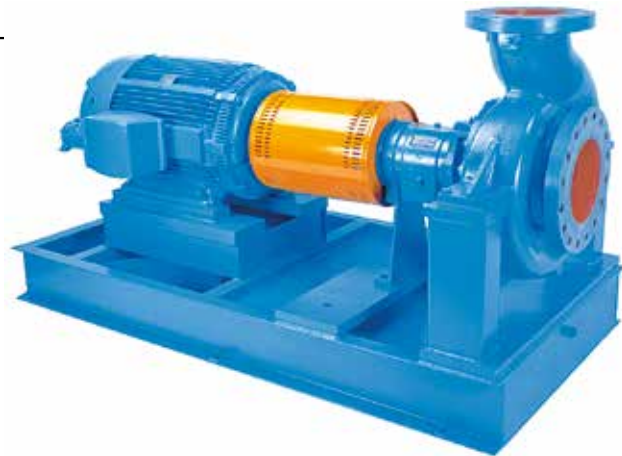

World-class Paper Stock and Medium Consistency Products

Goulds offers a variety of products in various configurations to meet your medium consistency pumping and mixing needs

Standpipe Arrangement with ClO₂ Mixing

Stock from washers and mixers feed special Goulds standpipes that are reverse tapered to prevent stock bridging. Systems include controls for vacuum, dilution, level and flow, ClO₂ Optimix™ mixer and chemical injection pipe are included.



Tower Bottom Arrangement

Stock from bleach / storage towers falls into Goulds feed chute connected to the tower with expansion joint and isolation valve. Depending on tower level and consistency a vacuum pump may not be required.



Booster Arrangement

Goulds booster pump will increase pressure, but does not require standpipe or degassing system.

Notes

Notes

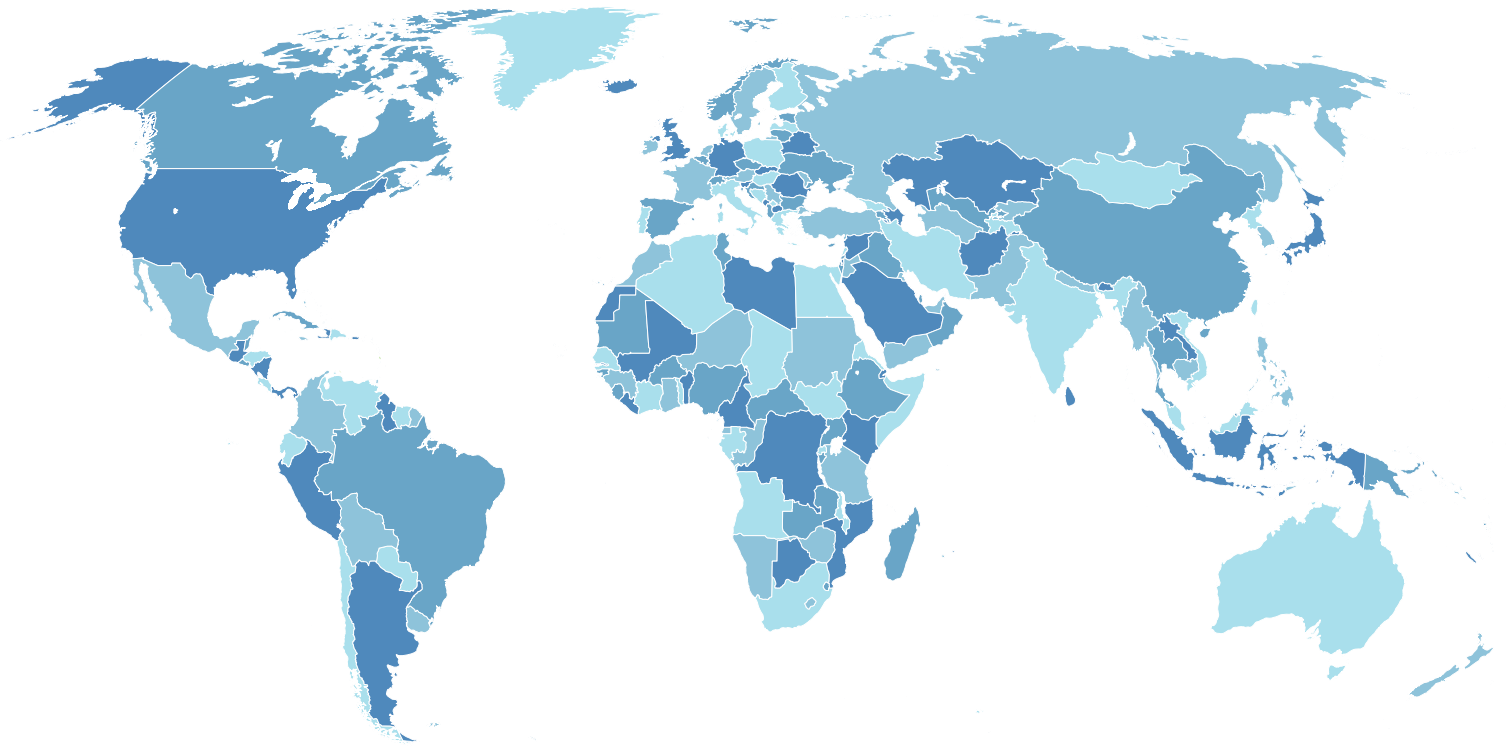

Visit www.ittproservices.com & www.gouldspumps.com to find nearest service, sales, and manufacturing locations



— An ITT Brand

240 Fall Street
Seneca Falls, NY 13148
Phone: 315.568.2811
Fax: 315.568.2418
www.gouldspumps.com

© 2025 ITT Goulds Pumps Inc.

B.3175.en-US.2025-01